

# Lock Replacement Guide

Fig. 1

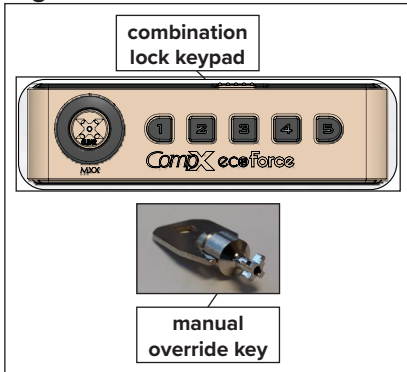

Fig. 2

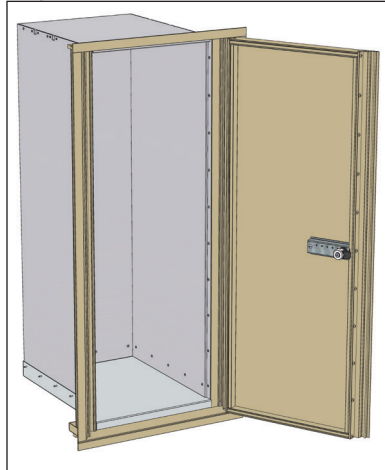

Fig. 3

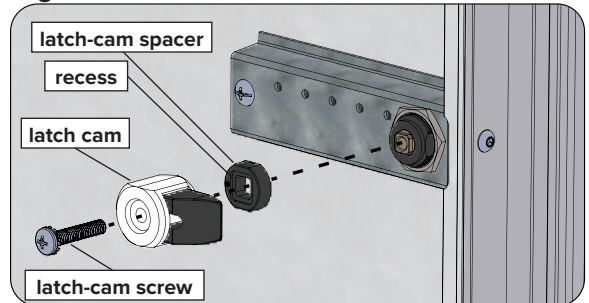

Fig. 4

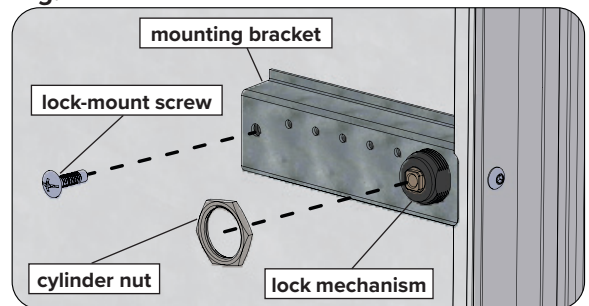

Fig. 5

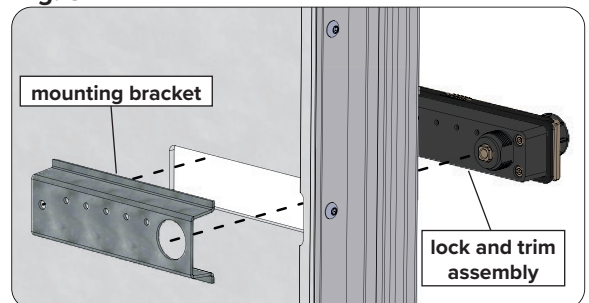
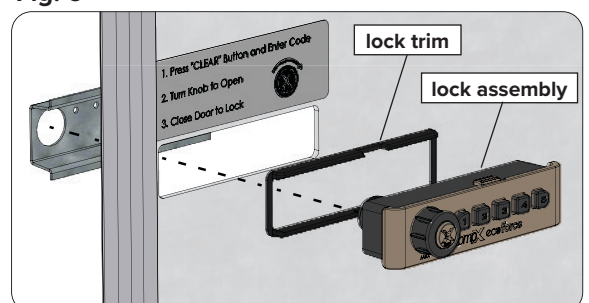

Fig. 6



## Remove the lock from the door.

1. Open the door of your Package Protector™ (Fig. 2) using the combination lock keypad, or the manual override key originally provided with your Package Protector™ (Fig. 1).
2. Remove the latch-cam screw from the back of the latch cam, using a Phillips screwdriver. Remove the latch cam and the spacer from the lock (Fig. 3).
3. Remove the lock-mount screw from the left side of the mounting bracket, using a Phillips screwdriver (Fig. 4).
4. Hold onto the lock on the outside of the door and unscrew the large cylinder nut from the lock mechanism, using an adjustable wrench (Fig. 4).
5. Remove the mounting bracket, lock, and lock trim from the door (Fig. 5).
  - Keep the mounting bracket for reuse when reinstalling the new lock.

## Install the new lock using new parts supplied with the lock.

1. Place the lock trim and lock onto the outside of the door (Fig. 6).
2. Place the original mounting bracket over the lock from inside the door and secure in place by finger tightening the large cylinder nut (Fig. 4).
3. Place the lock-mount screw through the left side of the mounting bracket into the back of the lock, and secure using a Phillips screwdriver. Tighten the cylinder nut, using an adjustable wrench (Fig. 4).
4. Position the latch cam and spacer onto the back of the lock mechanism. **Be sure the latch-cam spacer is oriented with the recessed side toward the latch cam, and the flat side toward the lock body.** Secure the cam and spacer in place with the latch-cam screw, using a Phillips screwdriver (Fig. 3).
5. Test the operation of the new lock to ensure it works properly before closing the door.